

# SYNEL SY-01ST – Tripod turnstile

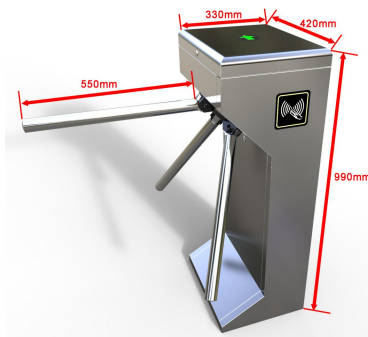

## Features

- SYNEL Main board owns manual function: Setting delay automatic door opening.
- SYNEL Automatic opening after emergency fire signal input.
- SYNEL Anti-following: prevent illegal passing.
- SYNEL Auto replacement function, re-position after person pass-by.
- SYNEL Anti-tail function auto lock once turns 120 degrees.
- SYNEL Arms auto drop when power off, insure unblocked when accident.
- SYNEL Standard electronic interface, remote control through internet which is also could connect variety card readers and receive relay signal to work.
- SYNEL Diverse control mode optional, changeable due to varying, convenient for your Manage.
- SYNEL Auto alert error function, comfort for user maintain and operate.
- SYNEL Manual button or remote control, Bi-directional passage.



**Synel order number -  
SY-01ST – 155090**

## Technical specifications

Power voltage	AC220±10%,50Hz	Open angle	120°
Drive voltage	AC12V+AC18V	Pass speed	≤30 person/minutes
Operation condition	-15°C~+60°C	Structure	SS304 Stainless steel
Relative humidity	≤95%, None-condensation	Open direction	Single and Double(optional)
Input signal	12v DC level or 12v pulse>100ms	Work environment	Outdoor and indoor
Working Current	≤2000mA	IP Degree	IP43
Length of the bar	510mm	Width of passage	≤550mm
Service life	≥5 million times	Machine sizes	420*330*980 mm