

Control System : All inputs are opto-coupler protected. Controlled by dry contact or grounding input. Compatible with all access control systems that provide dry contact or grounding outputs. Optional RS232/RS485/TCP IP control module is available.

Operation : Bi-directional passage, manually operated system.

Output Data : The system provides dry contact passage feedback by relays.

Flow Rate : Capacity of Mechanism - Manual System: ~97 passages/minute
Nominal: ~41 passages/minute (Recommended reference figure)

❖ **Explanatory Notes:**

- The above given figures are approximate for one person per walkway or lane.
- The system allows the new passage authorisation in less than ~0,3 seconds. After the passage authorization, the total passage time depends on the pushing and passage speed of the people.
- Utilisation of different access control units can change the flow rate.

Standard Features : Cut-out and acrylic cover for card reader mounting (when requested at the time of purchase order).

Optional Accessory and Applications:

Remote control units, interface unit for PC, RS485, RS232 and LAN, counter, automatic drop (retractable) arm, alarm sensor, card reader pole, heater positive unit, special design top lid, separator, floor mounting plate.

**Design and specifications are subject to change without notice.*

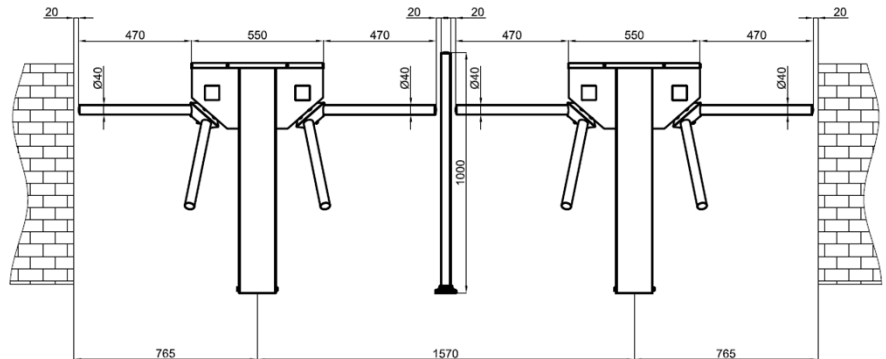
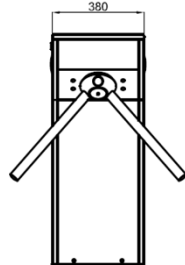
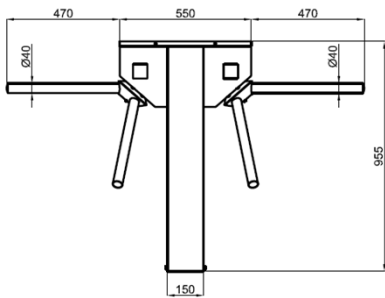
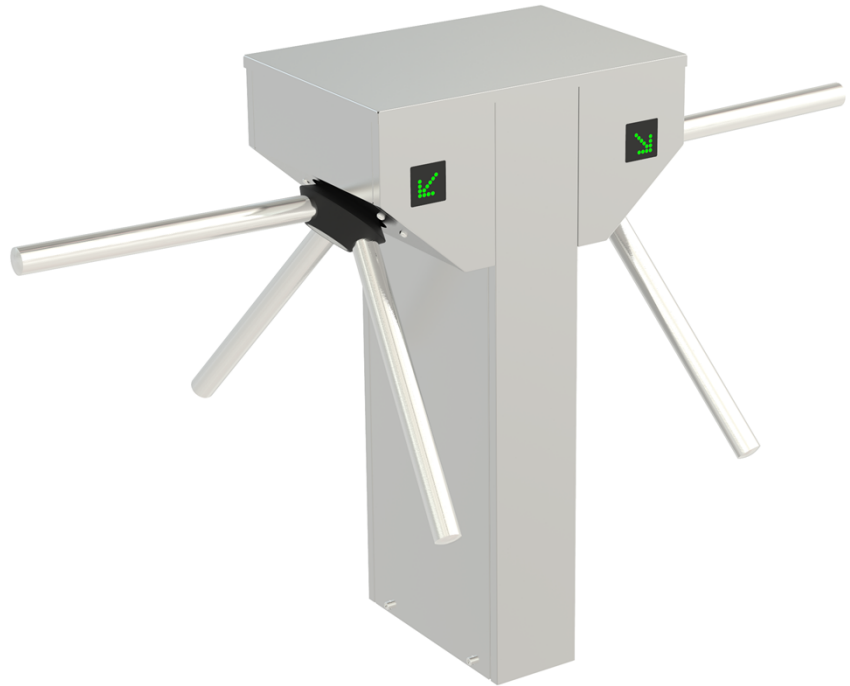
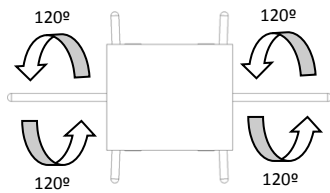

Power Requirements : 110/220V. 60/50Hz. AC (%±10) 24V DC. At standby ~11+11W. max. ~60+60W.

Dimensions : 380 x 550 (+ 2x470 arm length) x 955 mm

Arms : Ø40 x 2 mm 304-Grade (Opt. 316-Grade) stainless steel (Opt. anodised hard aluminium). Arms can be dismantled or mounted one by one separately.

Body Features : 304-Grade (Opt. 316-Grade) stainless steel with orbital brushed matt (opt. satin brushed) surface, flat and angular top lid versions with protection against water for outdoors use.

Indicator Features : Green Arrow & Red Cross LED as a standard feature.

Operating Temperature, Humidity, IP Rating

: -20°C to +68°C (Opt. -50°C with heater unit) / RH 95% non-condensing /
IP 54 Outdoor Model (Opt. IP 56)

Control System

: All inputs are opto-coupler protected. Controlled by dry contact or grounding input. Compatible with all access control systems that provide dry contact or grounding outputs. Optional RS232/RS485/TCP IP control module is available.

Operation

: Bi-directional passage, manually operated system.

Output Data

: The system provides dry contact passage feedback by relays.

Flow Rate

: Capacity of Mechanism - Manual System: ~97+97 passages/minute
Nominal: ~41+41 passage-per-minute

❖ Explanatory Notes:

- The above given figures are approximate for one person per walkway or lane.
- The system allows the new passage authorisation in less than ~0, 3 seconds. After the passage authorization, the total passage time depends on the pushing and passage speed of the people.
- Utilisation of different access control units can change the flow rate.

Standard Features

: Cut-out and acrylic cover for card reader mounting (when requested at the time of purchase order).

Optional Accessory and Applications:

Remote control units, interface unit for PC, RS485, RS232 and LAN, counter, automatic drop (retractable) arm, alarm sensor, card reader pole, heater positive unit, special design top lid, separator, floor mounting plate.

**Design and specifications are subject to change without notice.*